

# LAGUNA-50 LED SOLAR STREET LAMP

<https://horozelectric.com.ua>  
 +38 (096) 8312125

 Product&Family Code: **074 006 0050**

## Technical Drawing

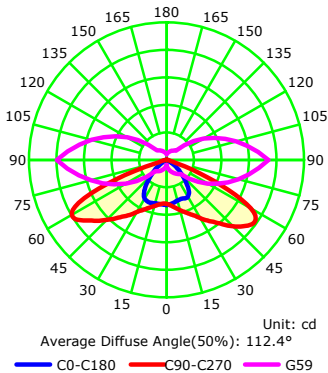
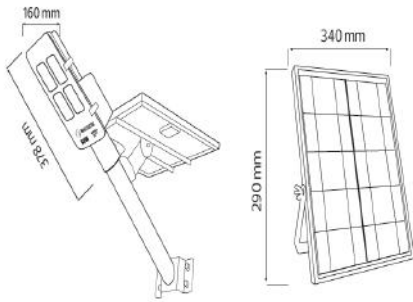

## Technical Data

Voltage (V)	3.2V/5Ah x 2 Lithium Iron Phosphate
Product Wattage (W)	50
Colour Render Index (Ra)	>Ra70
Colour Temperature (K)	6400K
Materials	Aluminium DIE-Casting + Glass
Protection Class	III
Dimmable	No
EEI	<b>A</b> to <b>A++</b>
Warm-up time up to 60 %of the full light output	Instant Full Light
Luminous Flux (lm)	950
Charging Time (h) :	4-6
Duration Time (hrs) ⌚	12-15H
Solar Panel	6V/12W(Polysilicon)
IP Rating	65
Beam Angle	120°
Pole Diameter (mm)	40
Installation Height(m)	3
Charging&Discharging Time:	> 1500

## Applications

- Street.



## Features

- High Lumen and CRI, Good quality & Constant Current driver.
- High heat dissipation, low carbon and environmental protection.
- SMD LED Lamp Base.
- Aluminum Body

